



Additional eCodes connection

You may add up to 3 additional eCodes to the same door extension.
The connection should be parallel to the first eCode.
You should configure the eCode's number.
In order to configure another eCode you must disconnect the others,
and configure one at the time, also the first one should be configured
as eCode 1.

Example: Set second eCode (after disconnected all the others)

		#719	*1234 *	78*	02 *
Dial ext.		Admin code	Operation code		eCode no.

Dial #711 to contact eCode 1
Dial #712 to contact eCode 2
Etc...

Open Door – answer phone and
press 8 .

Mic. Volume – answer phone and
press 4 – 4 volume modes.

Spk Volume – answer phone and
press 6 – 4 volume modes.

Initiate a call to the Panel – lift
handset and dial the panel
extension.

Connection and operation guide

eCode

Extension Door Phone for eMAX PABX
w/keypad for access

Programming

Program from ext. 1. Dial #719 to initiate connection with eCode, on eCode reply press:
 * admin code * operation code * value* . Default admin code is 1234

Operation description	code	Default value	Program sequence → → →
Change admin code	00	1234	#719 *1234* 00 * ???? *
Configure access code	01-50	1234	#719 *1234* 01 * ??<2-6 diffts>?? *
N.O relay active duration (s)	73	04	#719 * 1234* 73 * ?? *
Activation delay of relay when external button pressed	74	01	#719 * 1234* 74 * ?? *
Limit talk time with eCode (s)	76	60	#719 * 1234* 76 * ?? *
Reset all access codes	90		#719 * 1234* 90 *
Reset admin code			#719 * 4848* power off & on

Connection to Board

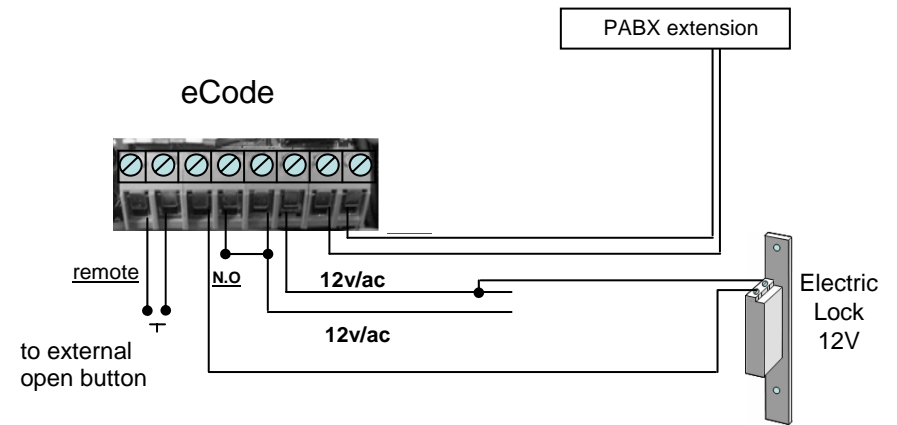

Name change

Remove screw as shown and remove black plastic cover.



Electric lock connection

